

# The journey of a ballot

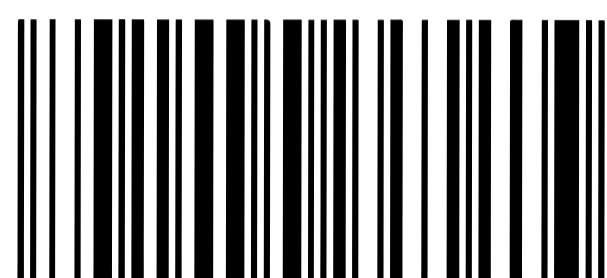

## BALLOT RECEIVING

Staff receive ballots from the U.S. post office and ballot drop box collection teams.



## BALLOT ENVELOPE SCANNING (FIRST PASS)

Staff scan ballot envelopes, capturing the unique ballot envelope ID and an image of the signature.

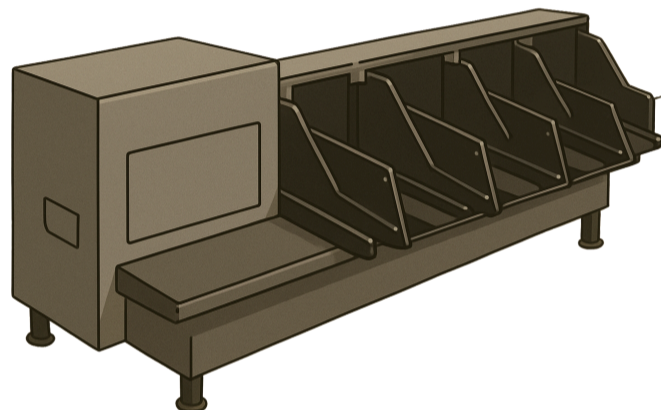

## BALLOT ENVELOPE SCANNING (SECOND PASS)

Staff scan ballot envelopes again, sorting ballots with accepted signatures into batches of ballots to be opened.



## SIGNATURE VERIFICATION

Staff compare voters' signatures on ballot envelopes to the signatures in their voter registration records to make sure they match.

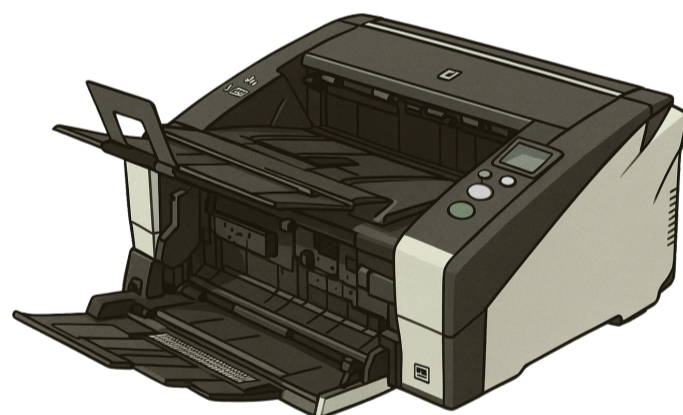

## BALLOT SCANNER

Staff scan batches of ballots into the secure, certified vote counting system. This system is never connected to internal or external networks.



## REVIEWING SCANNED BALLOTS

Staff work in teams of two to review and address scanned ballot images with voter corrections, damage, or unclear voter marks, ensuring accurate counting by the vote counting systems.



## RESULTS AUDITING

Staff conduct audits after Election day to confirm the accuracy of the ballot counting equipment and election results, prior to certification.

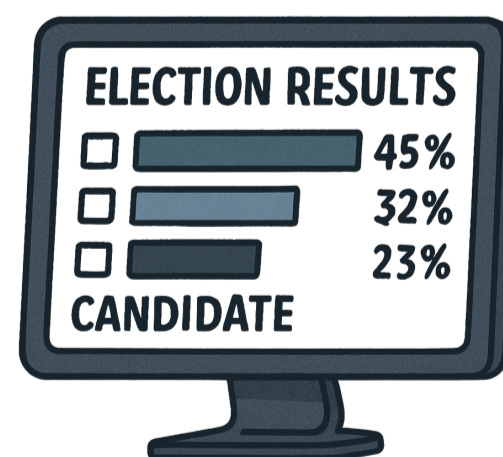

## RESULTS TABULATION

Two staff members tabulate initial election results no sooner than 8 p.m. on Election Night and regularly prepare updated results until the election is certified 10 to 21 days after Election Day.



## SECURE BALLOT STORAGE

Staff store ballots and detailed records from the election in secure containers and storage rooms in accordance with state and federal retention periods.

